

# Profile magnetic cylinder VDMA - ISO 15552 Series NWT

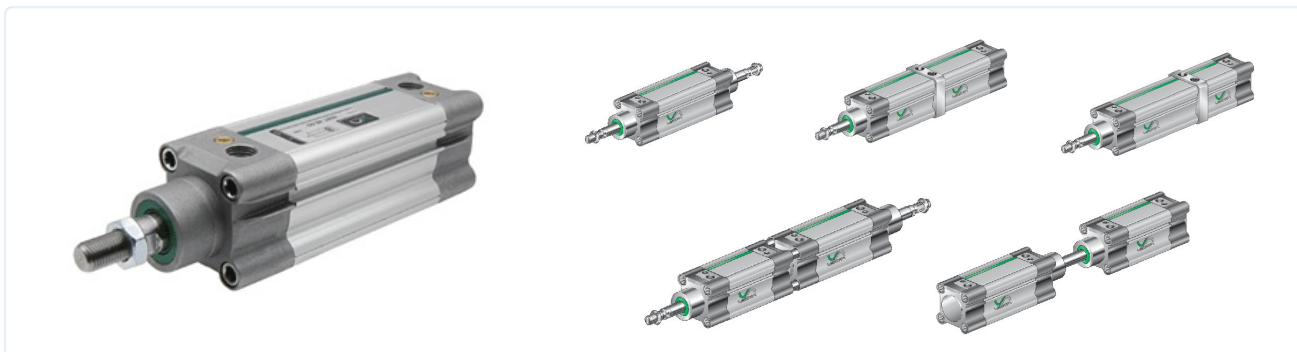

Design type	Profile magnetic cylinder according to VDMA - ISO 15552
Heads	High-pressure die-cast aluminium alloy
Piston rod	Stainless steel X20Cr13 rolled
Cylinder tube	Hard-anodized aluminium profile
Seals	Polyurethane
End-position cushioning	pneumatically adjustable
Stopper	mechanical
Ambient temperature	-10...+80°C (-5...+150°C for version FKM complete, Low-temperature version -30...+80°C)
Medium temperature	0...+40°C
Lubrication	not necessary
Medium	filtered compressed air
maximum operating pressure	10bar
Scope of delivery	incl. piston rod nut
Special versions	ATEX, for hazardous area (explosive atmosphere)
Note	Technical documentation for accessories see separate data sheet CAD files are available in the STASTO Store at <a href="http://www.stasto.eu">www.stasto.eu</a> Solenoid switch see separate data sheet

## Type code

NWT	__ -	___ -	__ -
	32 ø32	Stroke [mm]	__ double-acting
	40 ø40		P continuous piston rod
	50 ø50		SEA single-acting Front spring
	63 ø63		SEP single-acting Rear spring
	80 ø80		VS FKM Piston rod seal
	100 ø100		VV FKM complete
	125 ø125		LT Low-temperature version



### Standard strokes, Cushioning length

∅	25	50	80	100	125	160	200	250	300	350	400	450	500	600	700	800	900	1000	Cushioning length
32	•	•	•	•	•	•	•	•	•	•	•	•	•						24
40	•	•	•	•	•	•	•	•	•	•	•	•	•						27
50	•	•	•	•	•	•	•	•	•	•	•	•	•						30
63	•	•	•	•	•	•	•	•	•	•	•	•	•						30
80	•	•	•	•	•	•	•	•	•	•	•	•	•	•	•	•	•	•	36
100	•	•	•	•	•	•	•	•	•	•	•	•	•	•	•	•	•	•	38
125	•	•	•	•	•	•	•	•	•	•	•	•	•	•	•	•	•	•	38

Special stroke on request

### NWT ../... double-acting

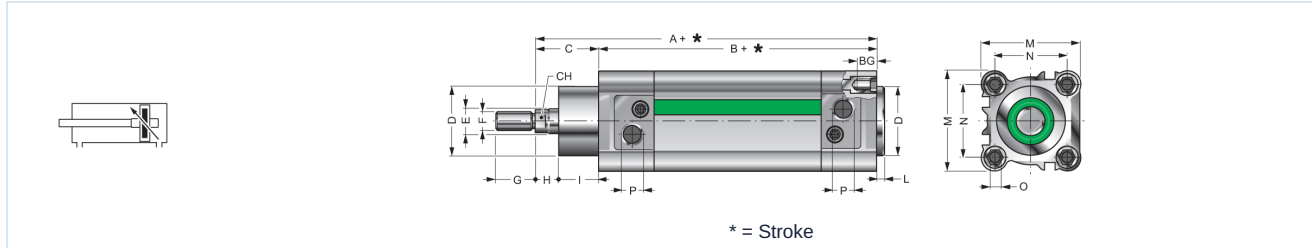

\* = Stroke

∅	A	B	C	D	E	F	G	H	I	L	M	N	O	P	BG	CH	Type
32	120	94	26	30	12	M10x1,25	20	8	18	4	45	32,5	M6	G 1/8	16	10	NWT32/...
40	135	105	30	35	16	M12x1,25	24	8,5	21,5	4	54	38	M6	G 1/4	16	13	NWT40/...
50	143	106	37	40	20	M16x1,5	32	9	28	4	64	46,5	M8	G 1/4	16	17	NWT50/...
63	158	121	37	45	20	M16x1,5	32	8,5	28,5	4	75	56,5	M8	G 3/8	16	17	NWT63/...
80	174	128	46	45	25	M20x1,5	40	11,5	34,5	4	93	72	M10	G 3/8	18	21	NWT80/...
100	189	138	51	55	25	M20x1,5	40	13	38	4	110	89	M10	G 1/2	18	21	NWT100/...
125	225	160	65	60	30	M27x2	54	30	35	5	142	110	M12	G 1/2	22	27	NWT125/...

### NWT ../... P double-acting, through piston rod

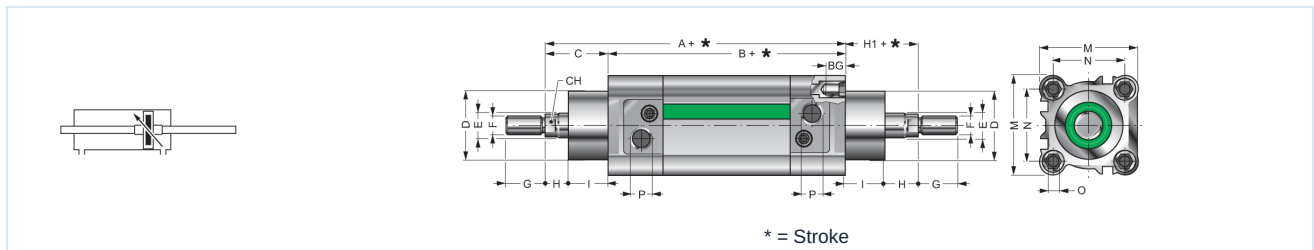

\* = Stroke

∅	A	B	C	D	E	F	G	H	H1	I	L	M	N	O	P	BG	CH	Type
32	120	94	26	30	12	M10x1,25	20	8	26	18	4	45	32,5	M6	G 1/8	16	10	NWT32/...P
40	135	105	30	35	16	M12x1,25	24	8,5	30	21,5	4	54	38	M6	G 1/4	16	13	NWT40/...P
50	143	106	37	40	20	M16x1,5	32	9	37	28	4	64	46,5	M8	G 1/4	16	17	NWT50/...P
63	158	121	37	45	20	M16x1,5	32	8,5	37	28,5	4	75	56,5	M8	G 3/8	16	17	NWT63/...P
80	174	128	46	45	25	M20x1,5	40	11,5	46	34,5	4	93	72	M10	G 3/8	18	21	NWT80/...P
100	189	138	51	55	25	M20x1,5	40	13	51	38	4	110	89	M10	G 1/2	18	21	NWT100/...P
125	225	160	65	60	30	M27x2	54	30	65	35	5	142	110	M12	G 1/2	22	27	NWT125/...P

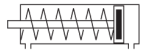
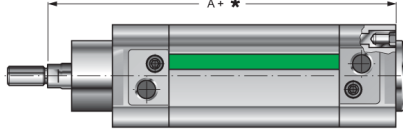

**NWT .../... SEA single-acting, spring front-mounted**

	 <p style="text-align: center;">* = Stroke for further dimensions see cylinder NWT standard</p>	Ø	A	Type
		32	120	NWT32/...SEA
		40	135	NWT40/...SEA
		50	143	NWT50/...SEA
		63	158	NWT63/...SEA
		80	174	NWT80/...SEA
		100	189	NWT100/...SEA

Stroke	Spring force [N]											
	Ø32		Ø40		Ø50		Ø63		Ø80		Ø100	
	min.	max.	min.	max.	min.	max.	min.	max.	min.	max.	min.	max.
10	50	54	72	82	110	123	110	123	166	180	166	180
20	44	54	62	82	98	123	98	123	152	180	152	180
30	40	54	52	82	86	123	86	123	137	180	137	180
40	35	54	42	82	73	123	73	123	123	180	123	180
50	30	54	32	82	60	123	60	123	110	180	110	180

**NWT .../... SEP single-acting, spring at rear**

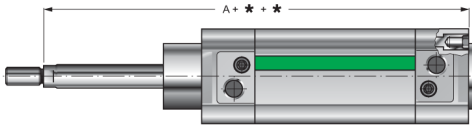
	 <p style="text-align: center;">* = Stroke for further dimensions see cylinder NWT standard</p>	Ø	A	Type
		32	120	NWT32/...SEP
		40	135	NWT40/...SEP
		50	143	NWT50/...SEP
		63	158	NWT63/...SEP
		80	174	NWT80/...SEP
		100	189	NWT100/...SEP

Stroke	Spring force [N]											
	Ø32		Ø40		Ø50		Ø63		Ø80		Ø100	
	min.	max.	min.	max.	min.	max.	min.	max.	min.	max.	min.	max.
10	50	54	72	82	110	123	110	123	166	180	166	180
20	44	54	62	82	98	123	98	123	152	180	152	180
30	40	54	52	82	86	123	86	123	137	180	137	180
40	35	54	42	82	73	123	73	123	123	180	123	180
50	30	54	32	82	60	123	60	123	110	180	110	180



**NWT ... TN2 ... Tandem**



NWT	__ /	__ TN2	__
	∅	Stroke	
			P continuous piston rod
			VS FKM Piston rod seal
			VV FKM complete

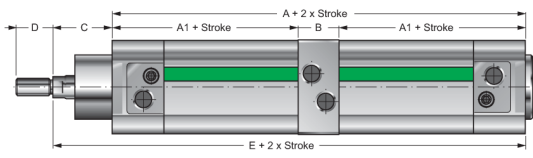

for further dimensions see cylinder NWT standard

∅	A	A1	B	C	D	E	Type
32	156	68	20	26	20	182	NWT32/...-...TN2..
40	175	73,5	28	30	24	205	NWT40/...-...TN2..
50	171	76,5	18	37	32	208	NWT50/...-...TN2..
63	191	85	21	37	32	228	NWT63/...-...TN2..
80	205	91,5	22	46	40	251	NWT80/...-...TN2..
100	224	98,5	27	51	40	275	NWT100/...-...TN2..
125	265	115	35	65	54	330	NWT125/...-...TN2..

**NWT ... BS ... Multi-position**



NWT	__ /	__ -	__ BS	__
	∅	Stroke 1	Stroke 2	VSFKM Piston rod seal
				VVFKM complete

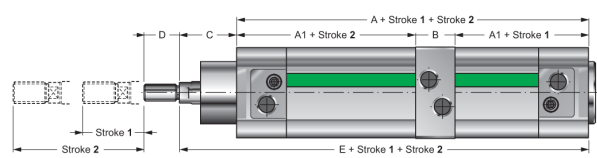

for further dimensions see cylinder NWT standard

∅	A	A1	B	C	D	E	Type
32	156	68	20	26	20	182	NWT32/...-...BS..
40	175	73,5	28	30	24	205	NWT40/...-...BS..
50	171	76,5	18	37	32	208	NWT50/...-...BS..
63	191	85	21	37	32	228	NWT63/...-...BS..
80	205	91,5	22	46	40	251	NWT80/...-...BS..
100	224	98,5	27	51	40	275	NWT100/...-...BS..
125	265	115	35	65	54	330	NWT125/...-...BS..

### NWT ... CNP ... Multi-position, bottom side



NWT	__ /	___ -	___ CNP	__
	∅	Stroke 1	Stroke 2	VSFKM Piston rod seal
				VVFKM complete

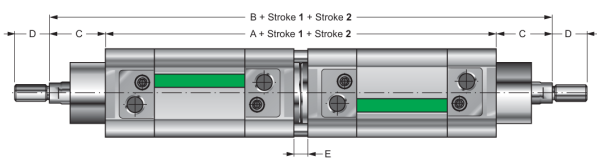

for further dimensions see cylinder NWT standard

∅	A	B	C	D	E	Type
32	196	248	26	20	8	NWT32/...-...CNP..
40	218	278	30	24	8	NWT40/...-...CNP..
50	220	294	37	32	8	NWT50/...-...CNP..
63	250	324	37	32	8	NWT63/...-...CNP..
80	264	356	46	40	8	NWT80/...-...CNP..
100	284	386	51	40	8	NWT100/...-...CNP..
125	330	460	65	54	10	NWT125/...-...CNP..

### NWT ... CNF ... Multi-position, piston rod side



NWT	__ /	___ -	___ CNF	__
	∅	Stroke 1	Stroke 2	VSFKM Piston rod seal
				VVFKM complete

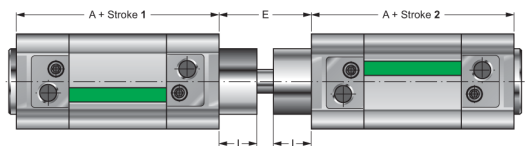

for further dimensions see cylinder NWT standard

∅	A	E	I	Type
32	94	48	18	NWT32/...-...CNF..
40	105	54	21,5	NWT40/...-...CNF..
50	106	69	28	NWT50/...-...CNF..
63	121	69	28,5	NWT63/...-...CNF..
80	128	86	34,5	NWT80/...-...CNF..
100	138	91	38	NWT100/...-...CNF..
125	160	100	35	NWT125/...-...CNF..

### Cover strip for profile magnetic cylinder series NWT



**NWT-PCC**

Illustrations non-binding  
Design, dimensional and material changes reserved